

# BATTLERS CONNECTION

## 3 Position Test Switch

### SPECS:

- Max Voltage: 30 VDC
- Configurable for either triple, dual with single, or 3 single input/output
- Max Amps 5

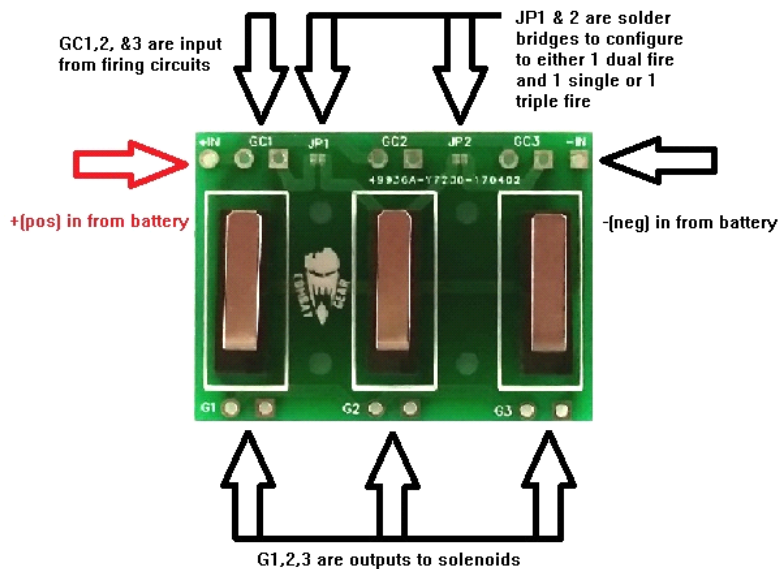

The above diagram notes both firing circuit inputs/outputs and Pos+/Neg- in positions we recommend 18-20AWG strand wire, 60/40 rosin core electrical solder with 25watt solder iron for completion of circuit. Install switches on white screen printed side with switch outlines the white box between sockets represents the Red button on micro switch.

### Operation of Switch:

- This circuit is designed to allow normal firing through radio control. Manual test firing of a single cannon is done through individual switch's without the requirement of radio control.
- For Triple configuration, solder bridge contacts JP1,2 (apply a bead of solder) with a single firing circuit input on GC1 only. Solenoid connections via G1,2,3
- For Dual w/ 1 single configuration, solder bridge contacts JP1 only (apply a bead of solder) install firing circuit input on GC1 for duals and single firing circuit on GC3. Solenoid connections via Duals G1,2 and single G3
- For 3 singles Do not solder bridge JP1,2. install firing circuits on GC1,2,3. Solenoid connections via G1,2,3
- +[pos] -[neg] are battery inputs for manual testing of cannons. Only -[neg] is required if using Combat Gear firing circuits. Connect both + and - if unsure of your firing circuit type.